

Engineering Project No.	Location	Change description	Author	Class	Document release status
ERN					

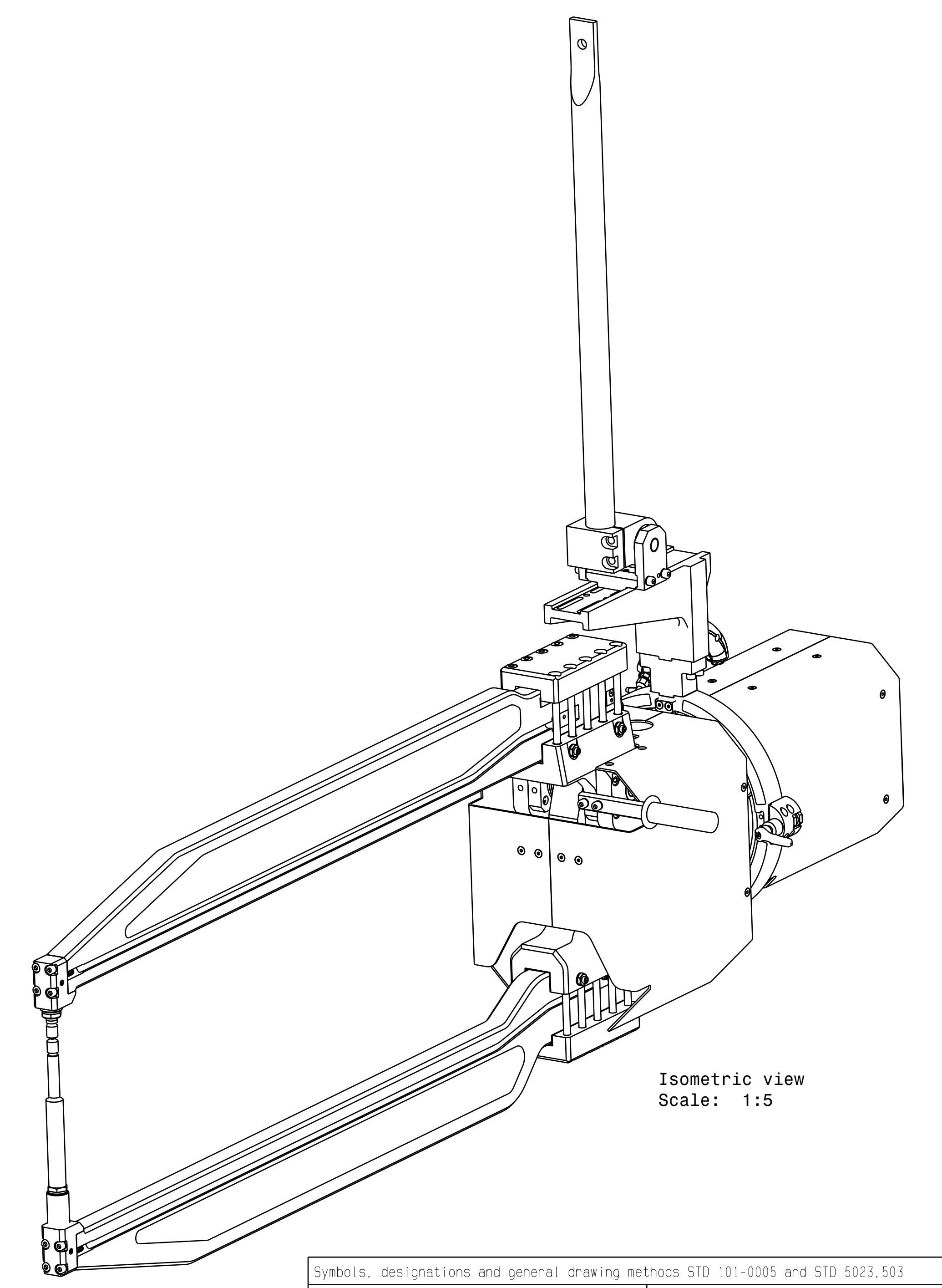
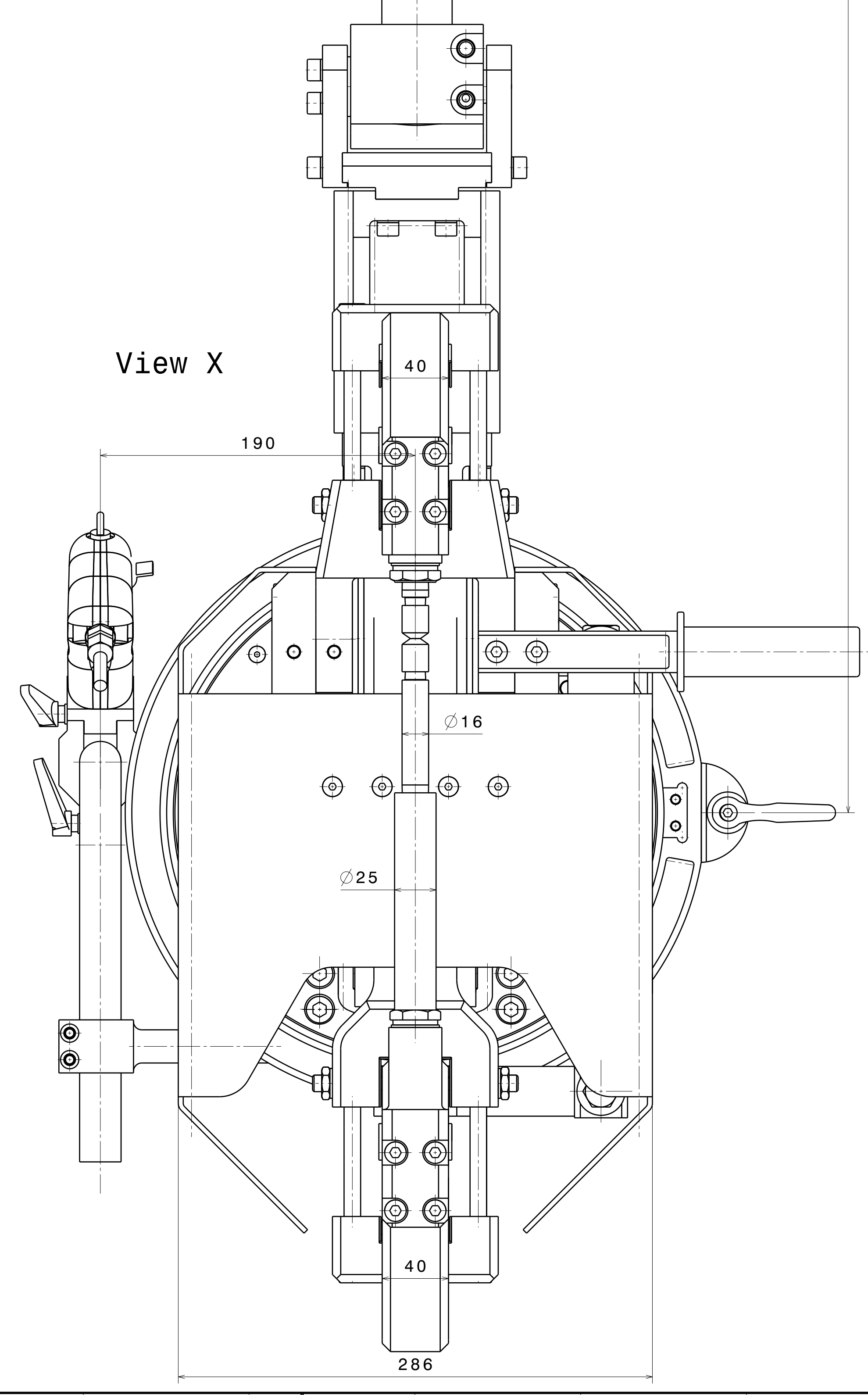
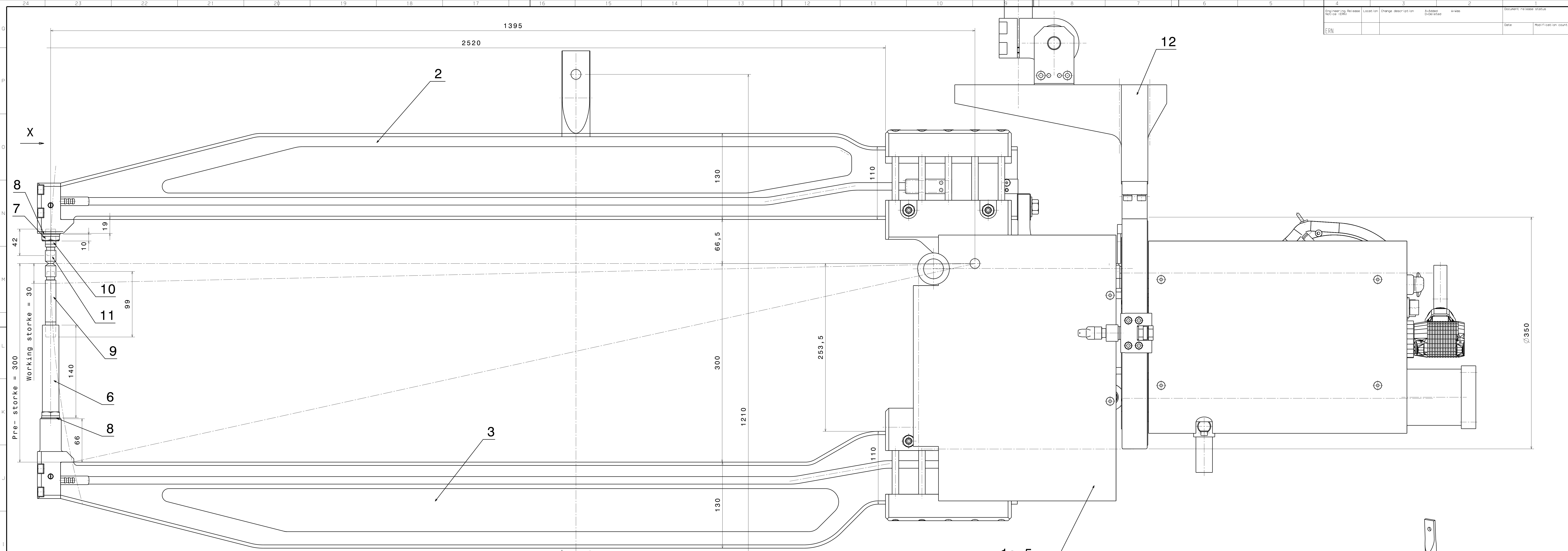

Weight 106kg  
 Transformer MF 3050  
 Cylinder force 6bar ca. 1700 daN  
 Pre-storke 35 mm  
 Working storke 40 mm  
 Electrode force 250 daN at 4,8 bar

Symbols, designations and general drawing methods STD 101-0005 and STD 5023.503					
Tolerance unless otherwise stated ISO 2768-m Sharp edges broken when function allows					
Drawn by	Date	Scale	Sheet	Title	
DRWB	12.07.08	1:2 (1:5)	1	Transformer Welding gun	
Company	Date	Project	Document type		
HELU-Service GmbH			Transformer Welding gun		
The drawing is the property of HELU-Service GmbH and its use is restricted to the project for which it was created. It is not to be reproduced or used for other projects without the written consent of HELU-Service GmbH.			Document No.		
VOLVO			Date: system Document prefix		
Volvo Truck Corporation			Document No.		
			3870 00506 000 0		